

Embedded non-volatile memory in standard logic CMOS
with no DRC violations and no added mask or process steps

Introduction

SoC application requirements for on-chip non-volatile memory (NVM) are rapidly expanding. Architects are quickly adapting to the availability of on-chip NVM with a number of uses such as those indicated below:

- Secure storage of encryption keys, ID, and other sensitive data
- Digital trim of analog circuits
- Self-healing circuit design
- Firmware storage
- Parameter storage
- Configurable logic
- Quality and yield improvement logic

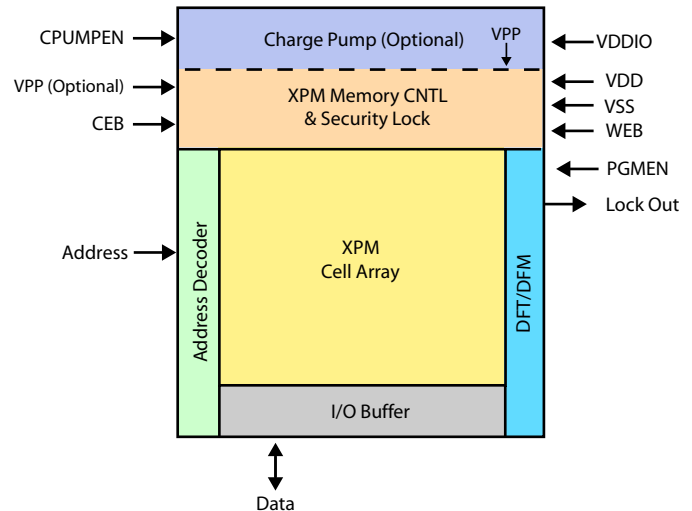

Products

XPM Registers (Physical IP)

- 16-bit OTP registers
- Instantiate N x 16-bits per requirements
- In-package & in-system programmable
- Register data always available
- High reliability (no soft errors)

XPM Memory (Physical IP)

- 1K-bit to 1M-bit XPM memory sizes
- Program Lock-bit
- In-package & in-system programmable
- Xtreme Security™: Physical security for secure storage applications
- Limited MTP application support
- High reliability (no soft errors)

Optional Charge Pump

- Support for XPM Registers & Memory
- No external V_{PP} required
- Proven in high volume production

Proven Process Support

- TSMC IP Certification for 180nm, 130nm, 90nm, 65nm, and 45nm
- Proven in high volume production
- Support for 65(GP, LP), 90nm (G, LP), 130nm (G), and 180nm (G) process technologies
- 40(LP) and 55nm(GP) planned for 2009

Proven Technology

XPM™ (Extra Permanent Memory) technology is based on a patented one-time programmable antifuse bit cell architecture invented by Kilopass' founder in 2001. Kilopass' first embedded NVM products were introduced on the 180nm (G) process node. Working closely with TSMC, Kilopass was the first vendor to deliver high density embedded NVM macros on the 130nm (G) process node; both 180nm and 130nm XPM IP products are now certified by TSMC. Continuing its leadership role, Kilopass now has its XPM macros qualified down to 45nm. XPM technology is already in a number of high volume consumer applications including video gaming and cell phones.

In support of the diverse requirements designers and system architects have for embedded non-volatile memory, Kilopass supports both XPM Register and XPM Memory products. For applications requiring continuous availability of programmed data for trim, calibration, and/or logic configuration, the XPM Register is ideal. For applications such as secure data storage and/or code storage, the XPM Memory leads the way with up to 1 M-bit of embedded NVM storage.

While XPM is a one-time programmable memory technology, due to its area efficiency, it is already being used in limited multi-time programmable (MTP) applications. This is made possible due to the fact that XPM memories are a fraction of the size of floating gate memory arrays of comparable sizes.

Xtreme Security™

Due to its small nanometer size characteristics, the antifuse has long been understood to provide the highest degree of physical security for the permanent storage of sensitive information in an integrated circuit. This advanced degree of physical security is ideal for design IP protection, as well as the protection of third party IP such as media content.